

SECTION A
SCALE 3/4" = 1'-0"
S9

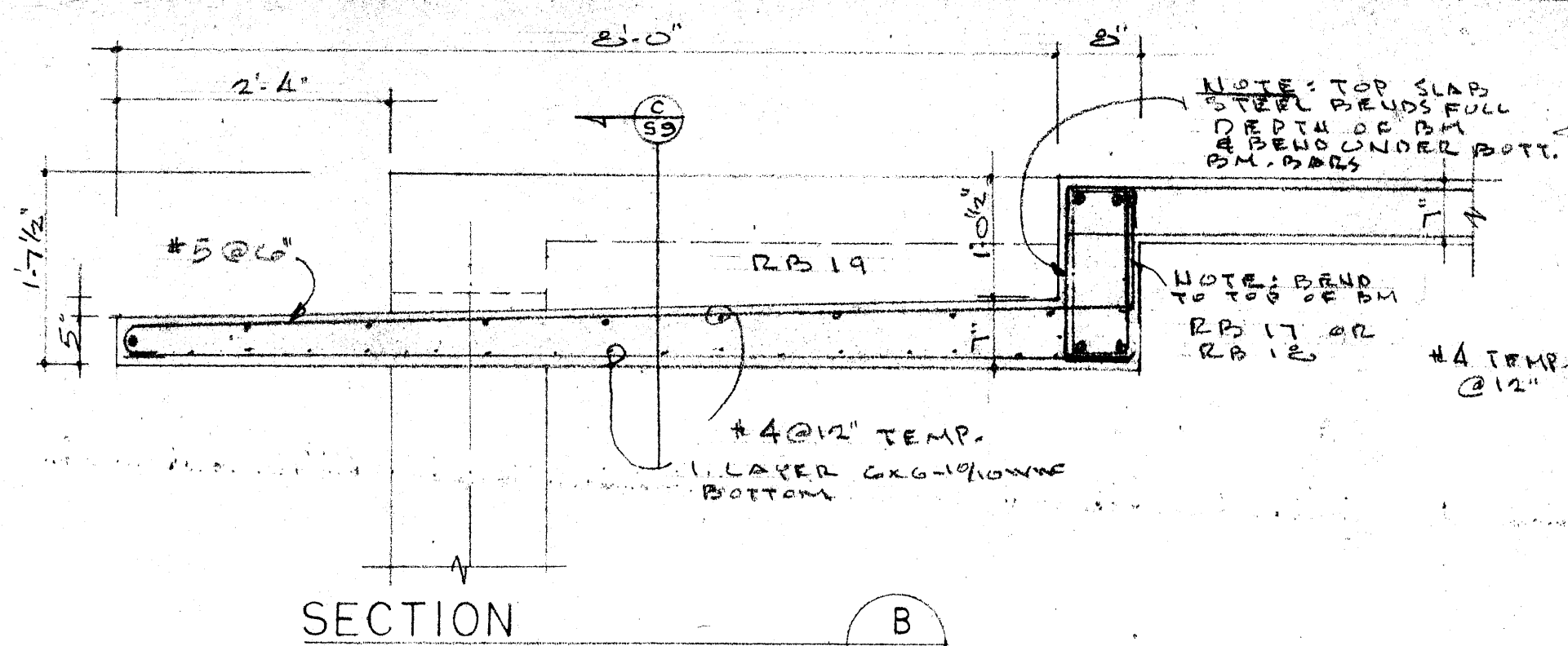

SECTION B
SCALE 3/4" = 1'-0"
S9

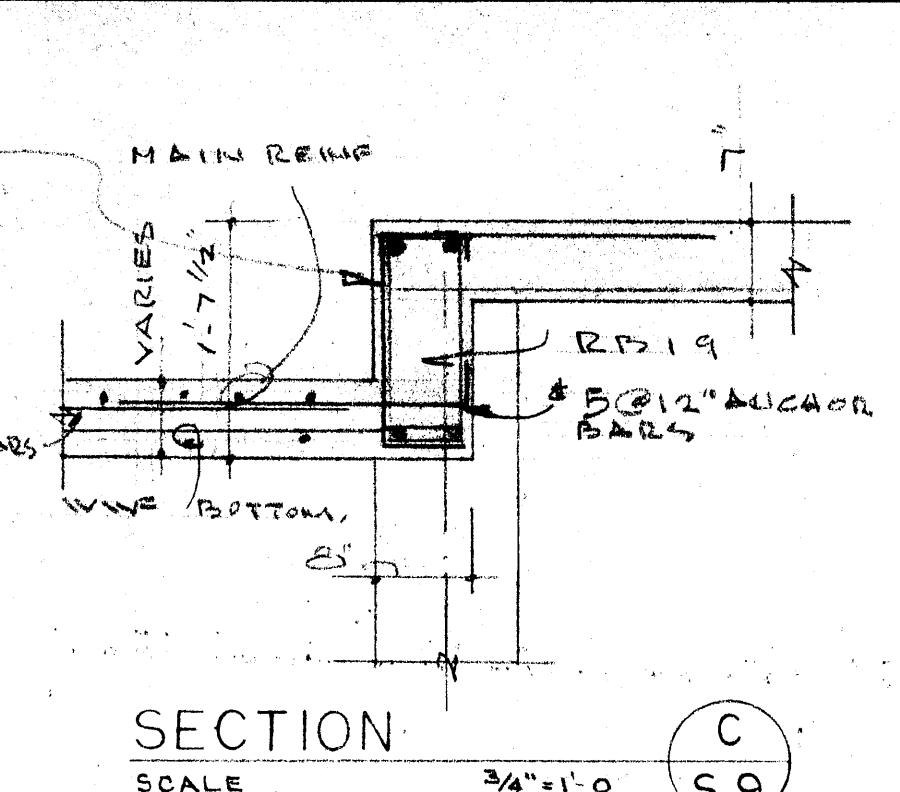

SECTION C
SCALE 3/4" = 1'-0"
S9

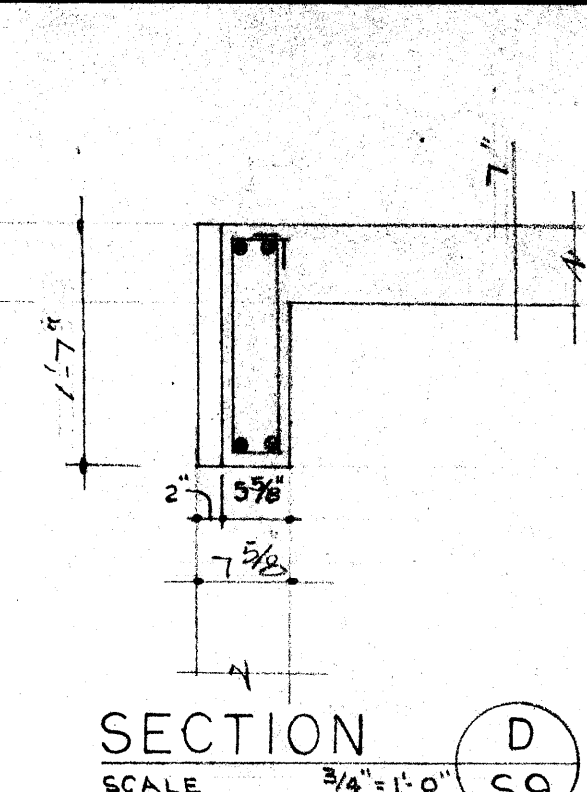

SECTION D
SCALE 3/4" = 1'-0"
S9

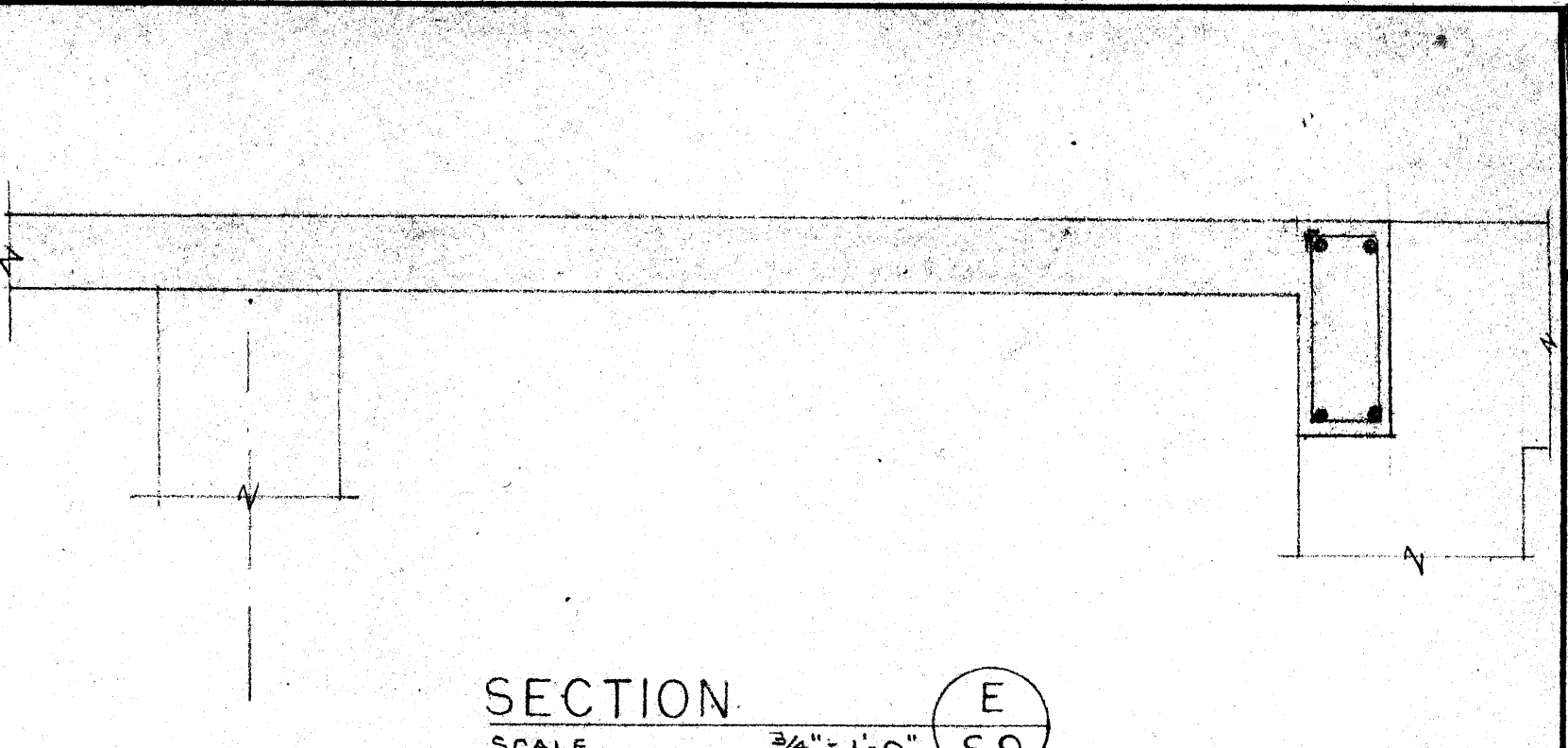

SECTION E
SCALE 3/4" = 1'-0"
S9

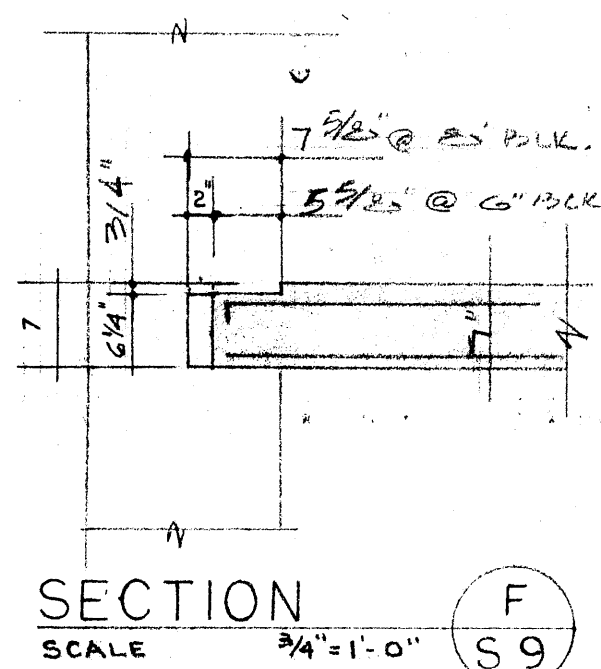

SECTION F
SCALE 3/4" = 1'-0"
S9

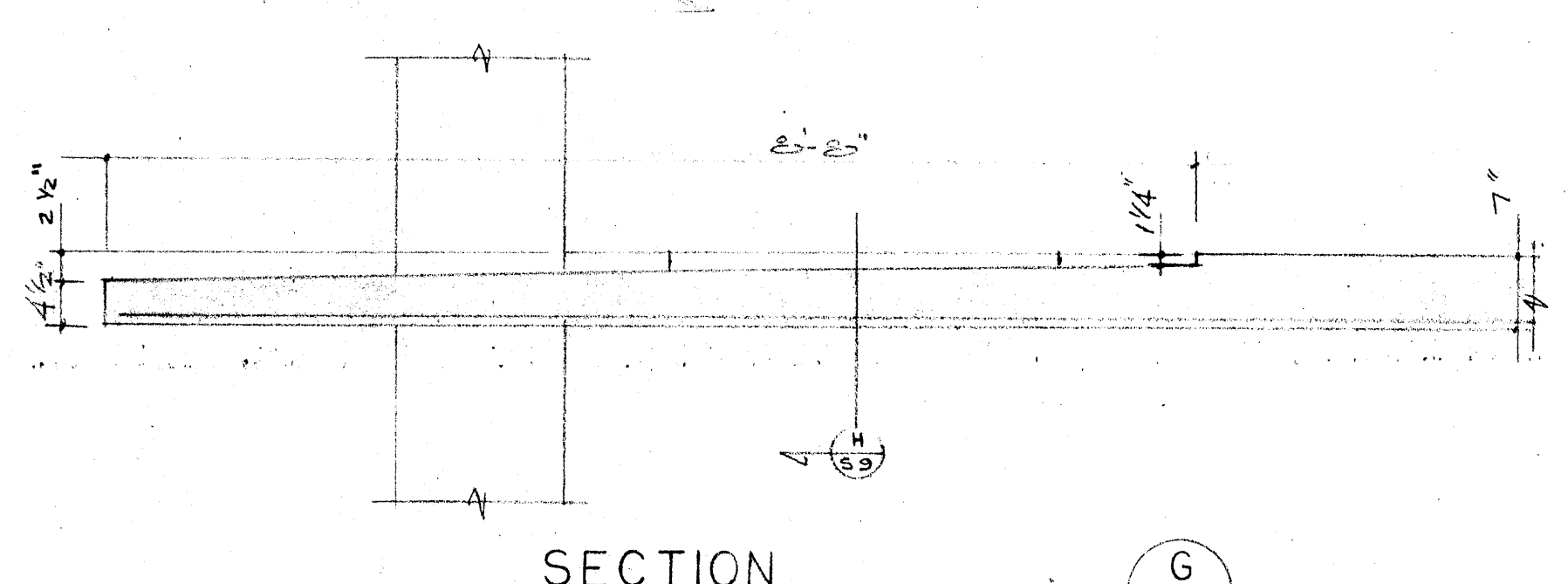

SECTION G
SCALE 3/4" = 1'-0"
S9

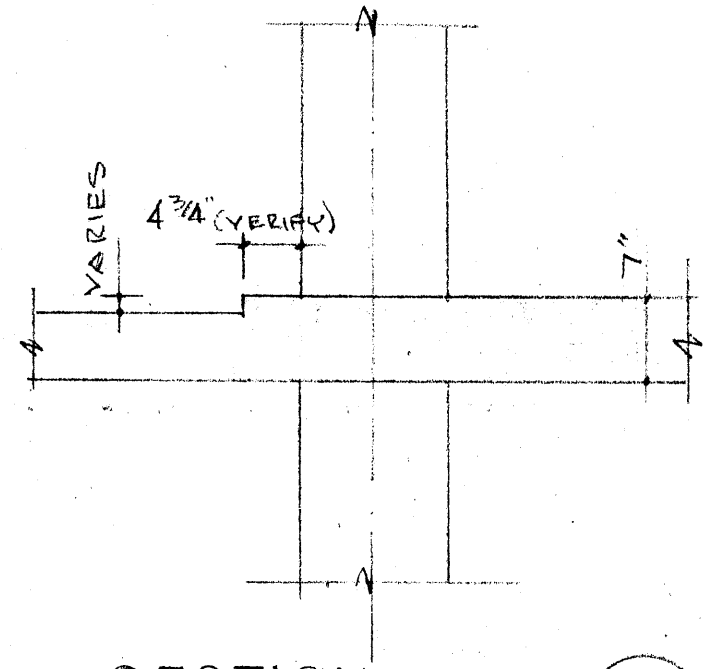

SECTION H
SCALE 3/4" = 1'-0"
S9

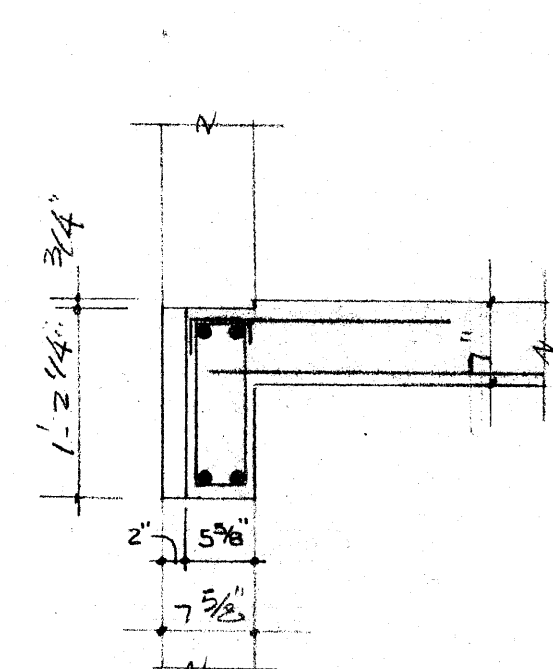

SECTION I
SCALE 3/4" = 1'-0"
S9

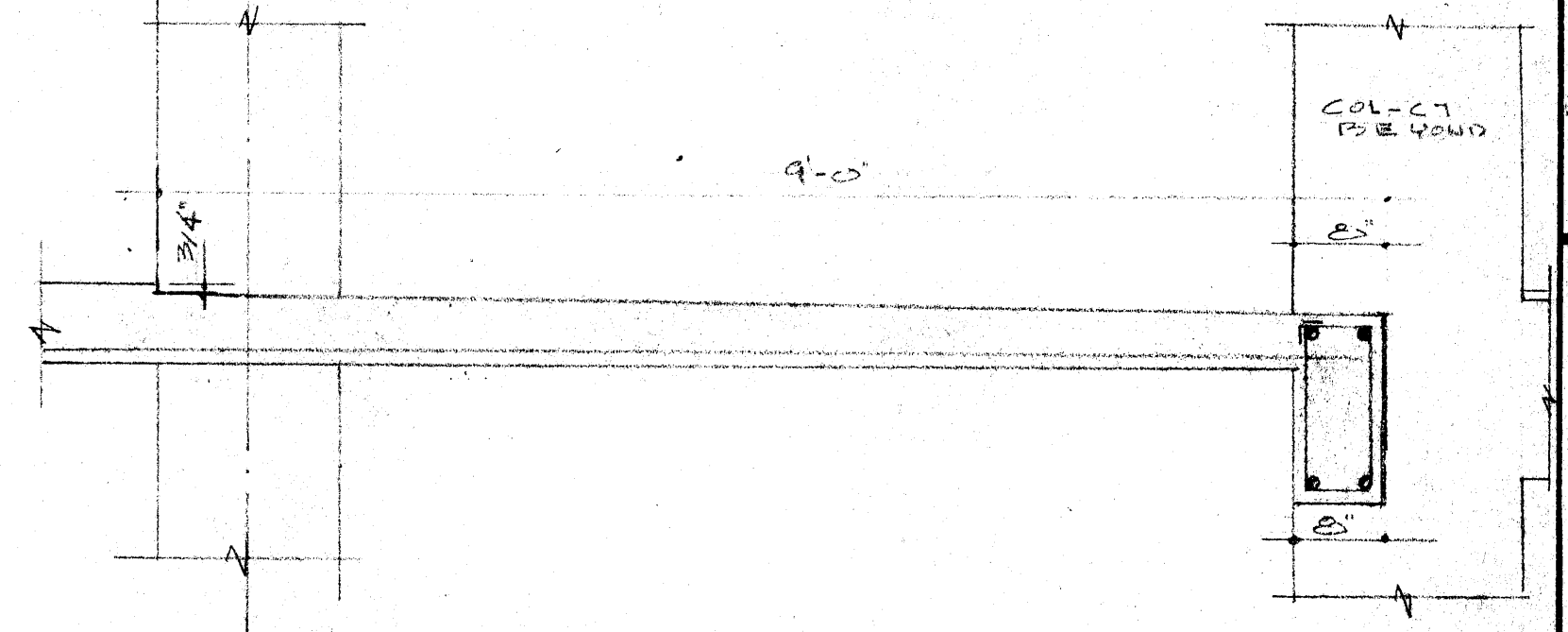

SECTION J
SCALE 3/4" = 1'-0"
S9

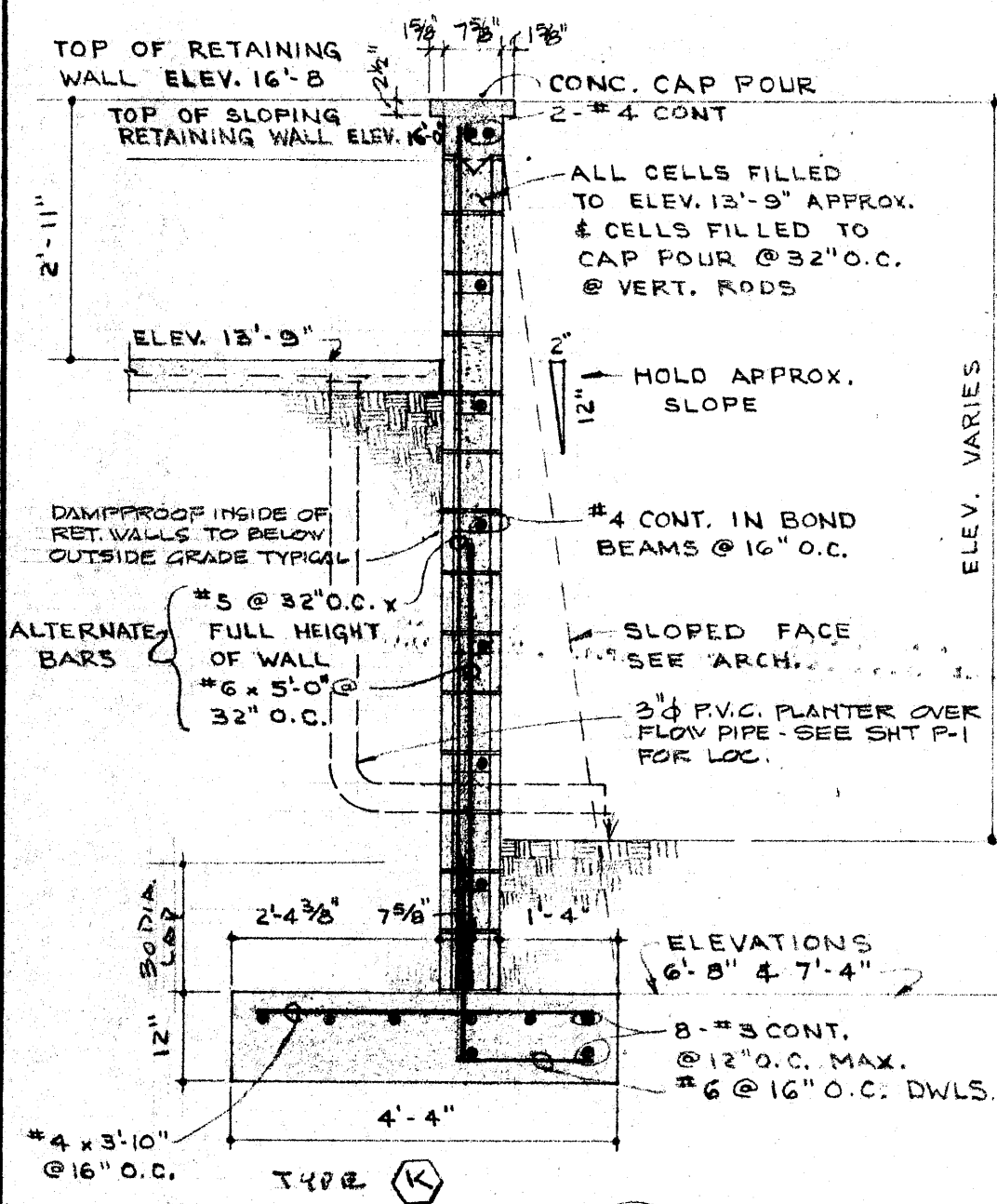

SECTION K
SCALE 1/2" = 1'-0"
S9

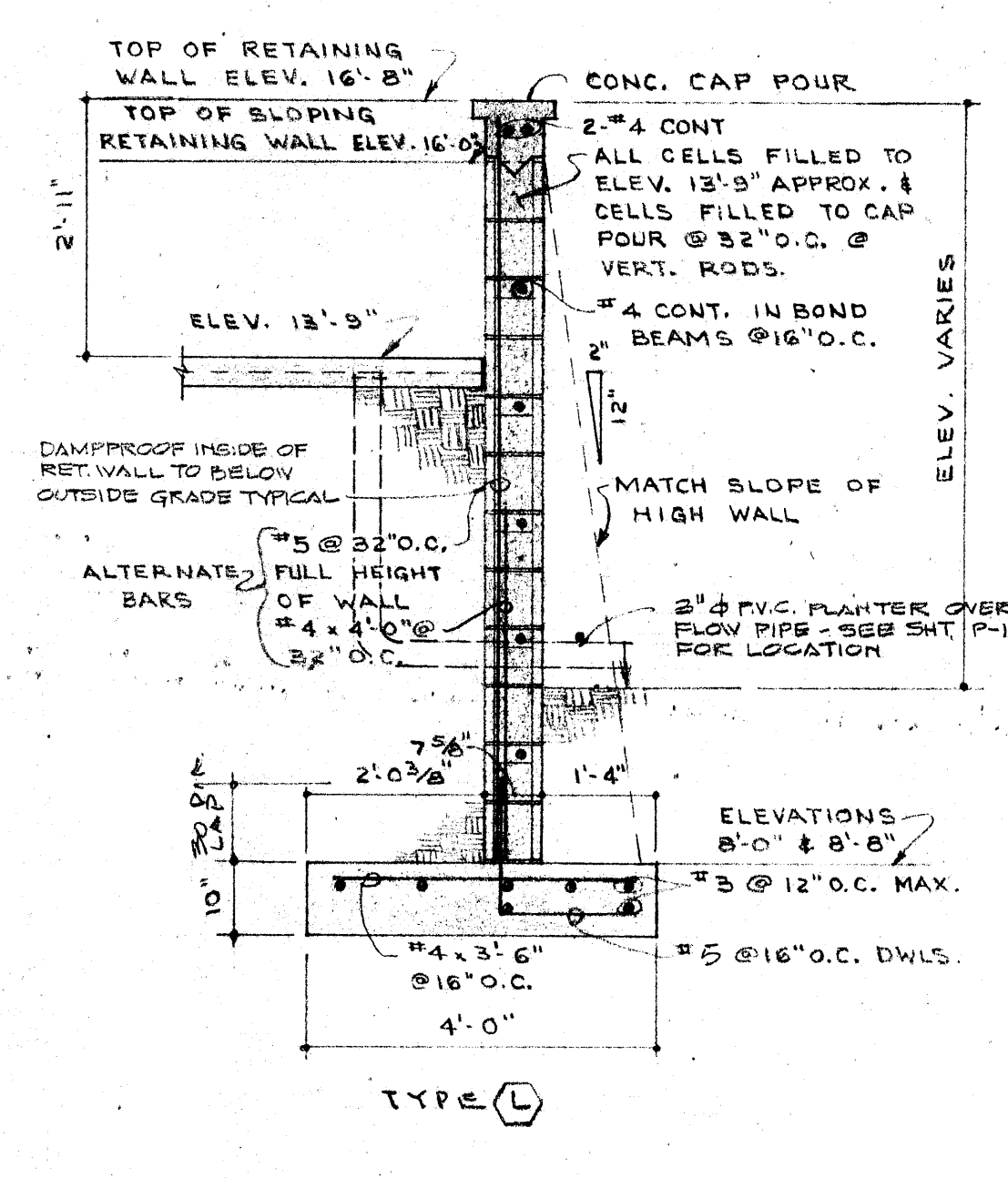

SECTION L
SCALE 1/2" = 1'-0"
S9

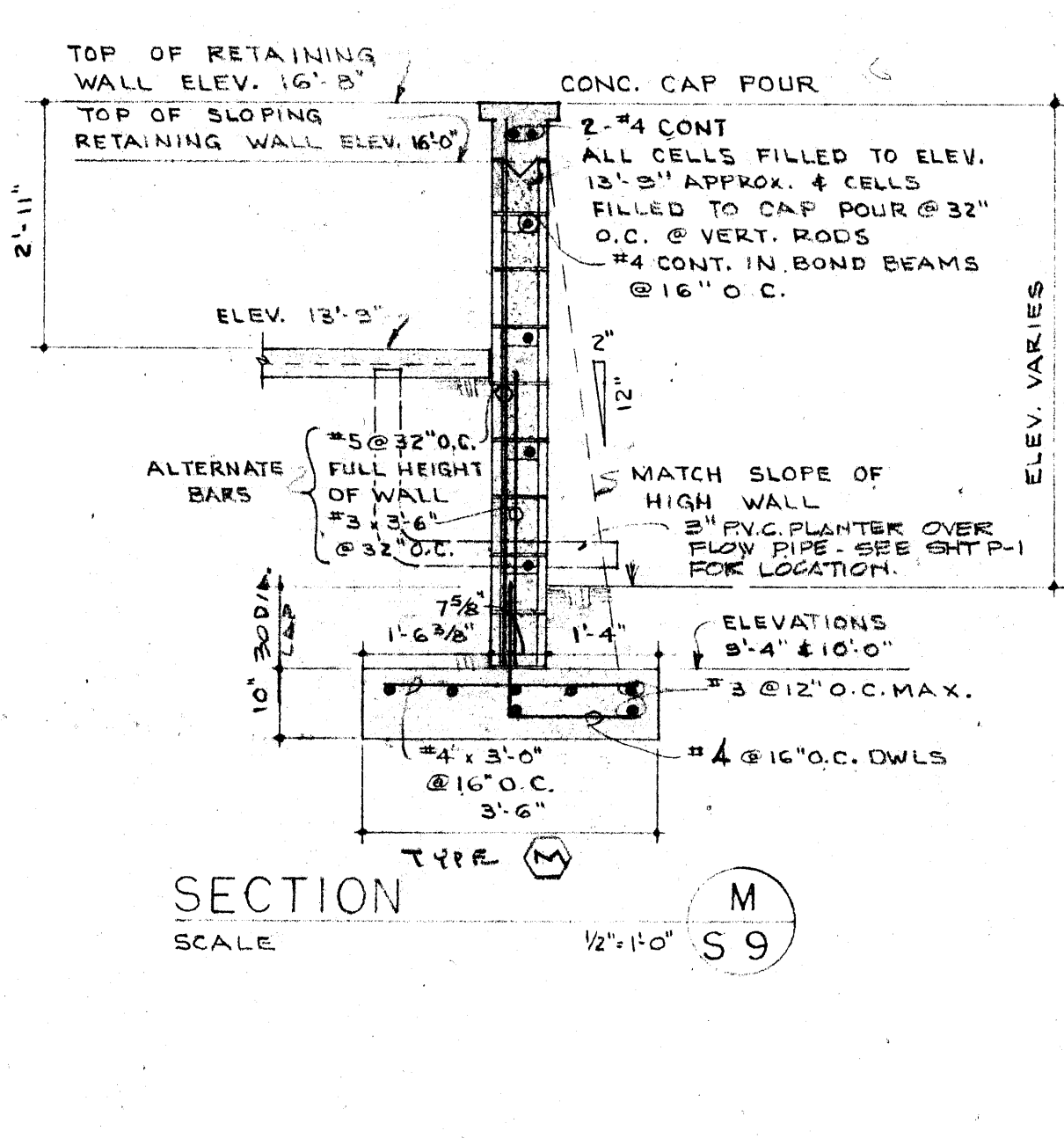

SECTION M
SCALE 1/2" = 1'-0"
S9

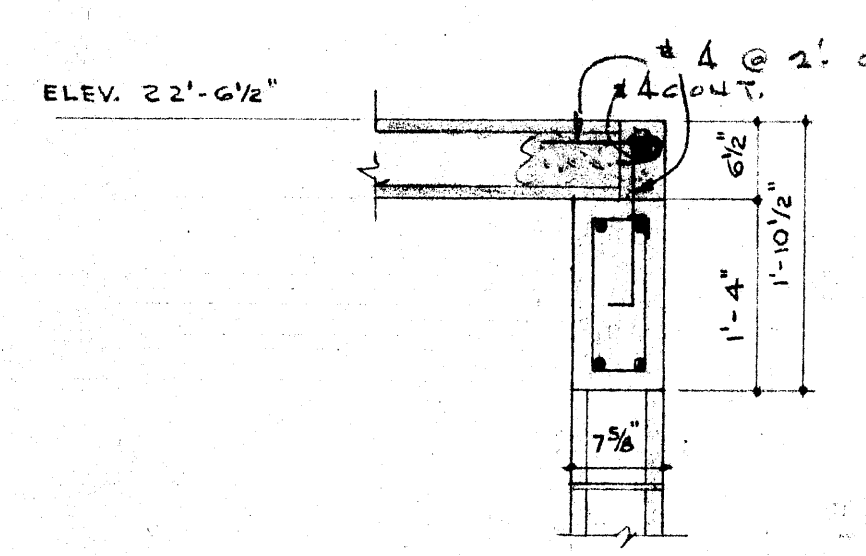

SECTION N
SCALE 3/4" = 1'-0"
S9

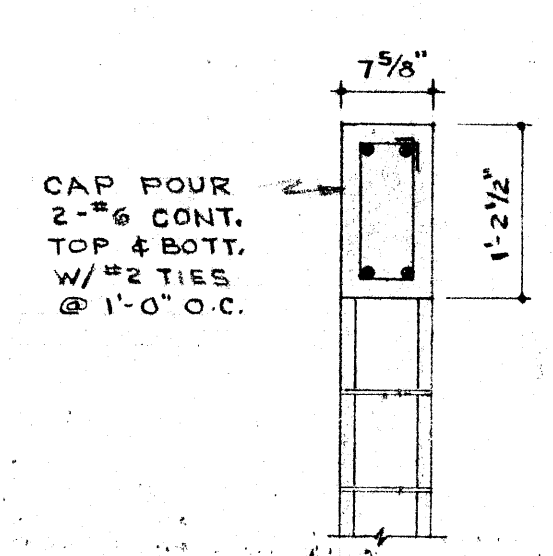

SECTION O
SCALE 3/4" = 1'-0"
S9

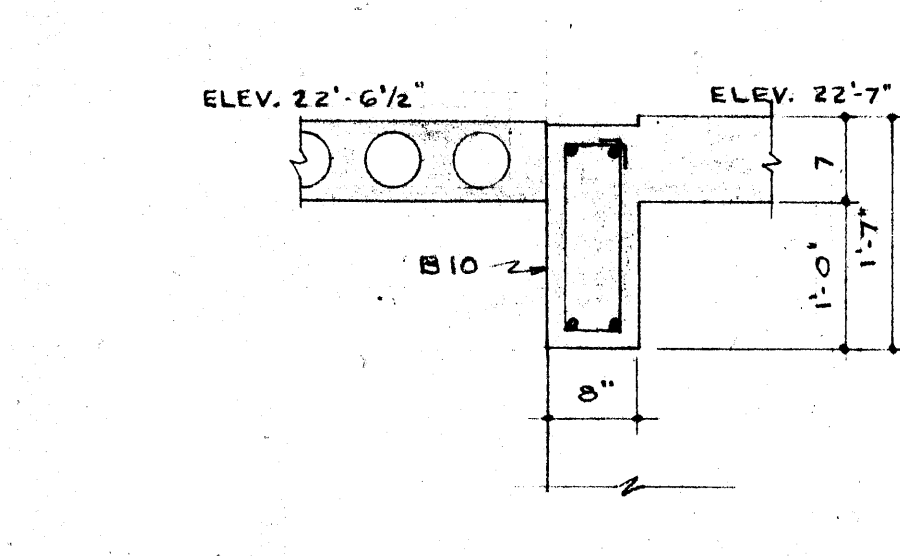

SECTION P
SCALE 3/4" = 1'-0"
S9

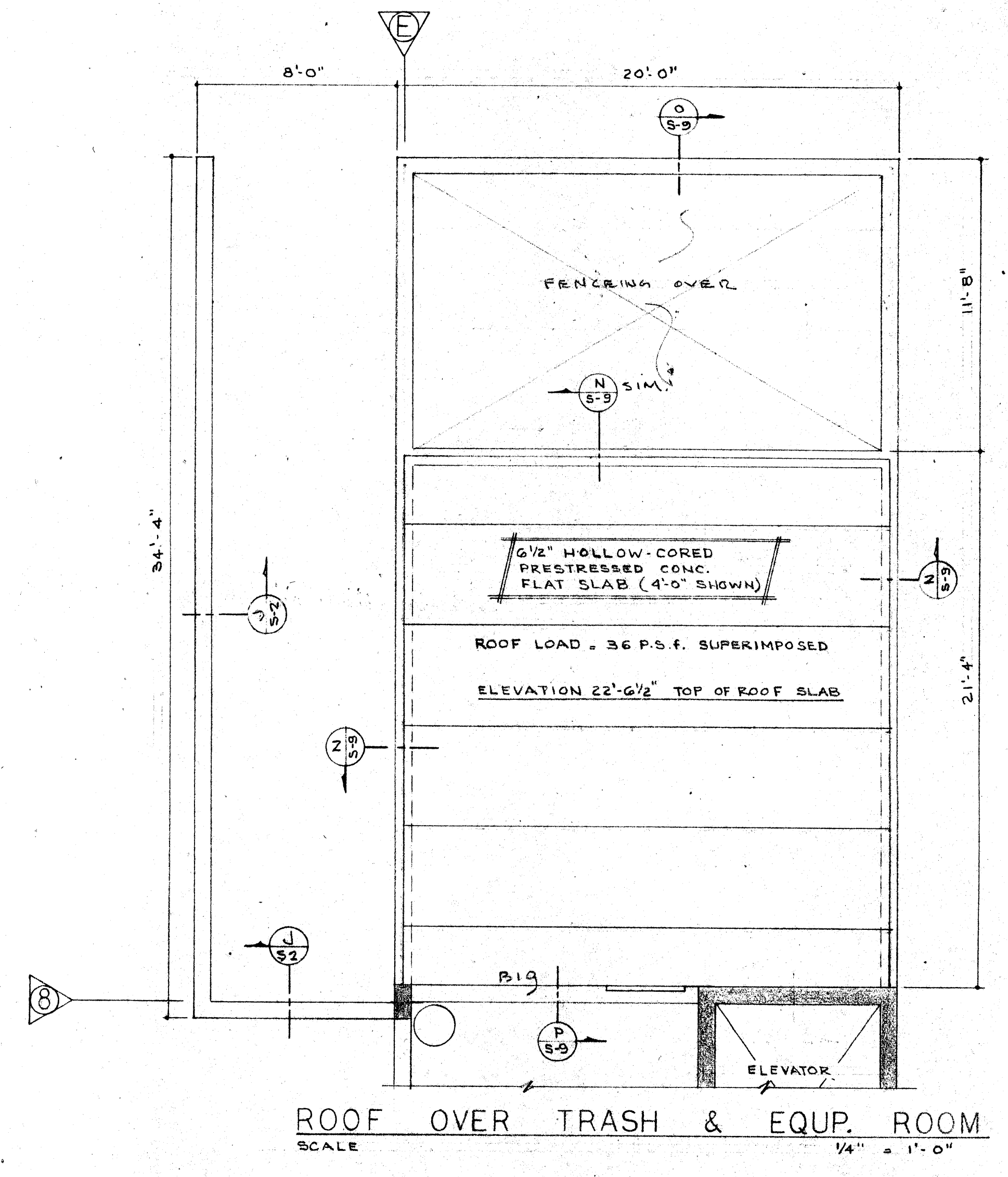

ROOF OVER TRASH & EQ. ROOM
SCALE 1/4" = 1'-0"